

## Brief Communication

# Oscillating Jet Flow in Enclosures with Non-circular Cross Section

Marek Scholler<sup>1</sup> and Udo Fritsching<sup>2</sup>

<sup>1</sup>Brno University of Technology, Faculty of Mechanical Engineering, Technicka 2, 61669 Brno, Czech Republic, e-mail: scholler@eu.fme.vutbr.cz

<sup>2</sup>University of Bremen, Chemical Engineering Department, Badgasteiner Str. 3, 28357 Bremen, Germany, email: ufri@iwt.uni-bremen.de

### Abstract

Liquid spray processes possess a typical spreading characteristics in an enclosing cavity. Therefore, the transient jet behaviour in a plenum or chamber with non-circular cross section is studied. The investigation is connected to problems in jet and spray processes where the process configuration of the flow needs to be investigated in order to achieve optimum working conditions and consequently to yield higher performance of the process. For investigation of the flow configuration numerical modeling and simulation has been used.

For analysis of the transient jet flow in enclosed areas full 3D geometries with transient simulations were employed for studying the oscillating jet behaviour in time and space. Aim of the study is the comparison of different chamber geometry variants with non-circular cross sections. Namely, some typical chambers with square and rectangular cross sections with and without streamwise expansion are compared. Two different types of movements are found in the rectangular cavity, namely precession and flapping movement of the jet. The calculations show that further expansion of the main chamber leads to decrement of the flapping and precession frequency in general, as well as an increase of the aspect ratio of D/H leads to a decrease of the flapping movement.

### INTRODUCTION

Technical spray processes e.g. for powder production by spray drying or melt atomization typically are realized in a configuration where a central spray or jet enters a plenum or chamber and leaves the chamber at the opposite side (Fritsching, 2006). The fundamental flow dynamics of this continuously operated process is that of a jet flow entering from a nozzle, moving through the chamber, and leaving the enclosure. Mixing processes in the bounded jet flow depend on its spatial and temporal behaviour. The formation of the jet in the bounded geometry under specific conditions may exhibit transient effects, where a precessing movement or flapping process of the jet between the chamber walls may occur depending on the geometry and the operational conditions (Heinlein et al., 2007). Such flow fields of transient jet flows in enclosures are in the focus of the present study.

In spray processes the transient spray or jet behaviour may cause severe technical problems. Here, e.g. the jet flapping may cause an intense droplet impact on the spray chamber walls. Droplets impinging on the wall may either result in a film formation or (for drying particles) in a deposition of a growing solid layer at the spray chamber wall. This droplet deposition certainly affects the process efficiency and may even result in cost intensive cleaning operations of the spray chamber. In addition, the jet flow in an enclosure or container will result in recirculation vortex formation in the spray chamber. In this recirculation flow spray droplets may be transported against the main spray direction from the regions near the chamber exit back to regions close to the atomizer location. This recirculation of spray particles may result in dust formation in the spray chamber because the smallest droplets will be preferentially entrained into the recirculating gas flow. Dust formation in the spray chamber may also decrease the spray process performance. The spray evolution in a spray chamber may be controlled by passive or active flow control mechanisms. A passive flow control may be achieved by an appropriate geometrical design of the spray chamber. Here, e.g. a minimization of the lateral extension of the spray

chamber may decrease the recirculation effect but will increase the destabilization of the jet flow, resulting in a transient unstable behaviour of the jet as mentioned above. An active spray flow control is achieved by integrating a superpositional secondary flow to the spray that is coflowing to the spray plume. In this way the jet is stabilized and the recirculation is suppressed. For evaluation of flow control mechanisms in spray processes in a first step one needs to look at certain limits of stationary or transient jet behaviour in spray processes and the process conditions when these transient effects may occur. In this way the present analysis of transient jet flow in a chamber with non-circular cross section is also aiming as the base of an analysis of flow control measures in spray processes.

Some previous studies on unsteady jet behaviour in processes are described for enclosures with *cylindrical and conical geometry variants*. Several different geometry variants are described and discussed by Guo et al. (2001). The principal arrangement of this study is illustrated in Figure 1. All the dimensions have been derived from this basic parameters, where the length of the chamber is  $L \sim 10D$ , the length of the inlet is  $l = 10d$ ,  $D$  is the outlet diameter and  $d$  the inlet diameter. Air is used as the working medium and the velocity magnitude in the jet inlet ( $U_1$ ) is prescribed. These parameters may be combined to the relevant non dimensional parameters of the expansion ratio  $E = D/d$  and the Reynolds number  $Re = U*d/\nu$ , where  $U$  is the axial velocity,  $d$  is the characteristic dimension and  $\nu$  is the kinematic viscosity of the working medium.

This paper deals with the investigation of the jet behavior in *rectangular chamber geometries* because some typical spray process applications are using a rectangular plenum chamber. Different geometrical variants derived from basic parameters have been investigated and compared with respect to their transient behaviour.

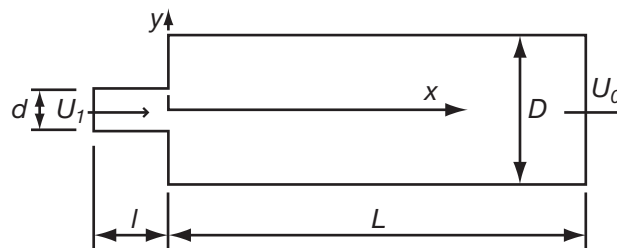

Figure 1. Basic configuration for jet behaviour studies in enclosures

## DESCRIPTION OF THE CFD MODEL

Numerical flow simulation is used to study the bounded jet behaviour in enclosures. The governing equations describing the unsteady jet behaviour namely are the conservation equations for mass and momentum. These are used in incompressible form, the density is assumed as constant. For closure of the equation system, as an appropriate turbulence model to be employed for solving these jet type problems, the renormalization group model of turbulence (RNG  $k-\epsilon$ ) has been used.

For the temporal discretization an implicit Euler scheme is used, though of low order order accuracy it obtained stable results. The PISO pressure coupling is used and the 3<sup>rd</sup> order QUICK spatial scheme for convective terms discretization is used in the transport equations. The working fluid was defined as incompressible and Newtonian. For all solved variants fully three-dimensional structured grids have been used. The total number of grid cells of app. 250.000 has been varied (local grid refinement), obtaining unchanged results in terms of the derived oscillation frequencies, therefore can be named a grid independent solution. The cell density has been generated with respect to the criterion that the wall distance of the first grid node  $y^+$  needs to be in between 30 to 500 (this criterion is applicable for models of turbulence with wall functions). The time step spacing was adapted to achieve maximum Courant numbers of about 10.

As inlet boundary condition, the velocity magnitude is prescribed (constant across the inflow area), the turbulent kinetic energy at the inlet has been prescribed to  $k = 0.05 = \text{const}$  with a length scale for the dissipation rate of  $l = 0.002 = \text{const}$ . For comparison of all variants, at the chamber outlet a constant pressure has been assumed, where the relative pressure has been set to zero.

Verification of the simulation has been performed by means of comparing simulation results for the case of steady state spreading of a free jet emerging from a circular nozzle into open space (see Rotta, 1972, Rajaratnam, 1976, Gillandt et al., 1997).

### RELEVANT PARAMETERS DESCRIBING JET FLOWS IN NON-CIRCULAR ENCLOSURES

When an oscillating or flapping movement of the jet occurs, the Strouhal number ( $St$ ) is the relevant criterion to describe the behavior of the jet. The Strouhal number can be evaluated as follows, where  $M$  is jet the momentum flux:

$$St = \frac{f \sqrt{\rho} \cdot D^2}{\sqrt{M}}, \quad (1)$$

$$M = \frac{\pi}{4} \cdot d^2 \cdot \rho \cdot U^2. \quad (2)$$

The Strouhal number according to eq. 2 is defined for cylindrical geometries, however for rectangular geometries one can modify this equation as

$$St = \frac{f \cdot \sqrt{\rho} \cdot D^2}{\sqrt{M}} \cdot \left(\frac{H}{D}\right)^{0.5} \quad (3)$$

to accommodate numerous geometric variations. Here both  $D$  and  $H$  refer to the cross-stream dimensions of the downstream chamber, as indicated in Figure 2.  $D$  is the width in the flapping direction and  $H$  is the dimension in the normal direction to the flapping. There are also other approaches to evaluate Strouhal number in the literature. The Strouhal number in a general form is expressed as

$$St = C E^n f d / U_i \quad (4)$$

where the coefficient  $C$  and the exponent  $n$  are listed in table 1. The exponent represents the sensitivity of the precession frequency to the expansion ratio.

Table 1. Coefficients and exponents for the Strouhal number

	Nathan et al. (1998)	Hill et al. (1995)	Hallet & Gunther (1998)
$C$	1	$2/\pi$	$2/\pi$
$n$	0	2	3

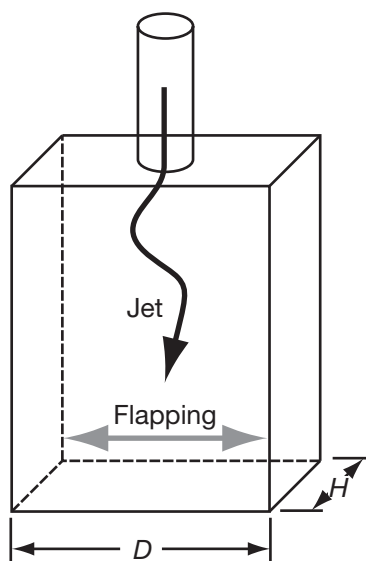

Figure 2. Schematic diagram of the dimensions for definition of the Strouhal number for a non-circular chamber

## LITERATURE SURVEY

Since the  $k-\varepsilon$  model and its variants of turbulence are reliable only for high Reynolds number flow in of the order of  $10^4$  or higher, the Reynolds number for all variants has been set in this range. According to Guo et al. (2001) the Strouhal number is increasing with the expansion ratio and is almost insensitive to the Reynolds number. For the case of the expansion ratio  $E = 5.0$ , the Strouhal number changes by only 3% within the Reynolds number range considered. On the other hand, the data of Hill et al. (1995) and Nathan et al. (1996) have relatively low Reynolds numbers and a wider range of expansion ratios from 3.75 to 14.

There it is shown that the Strouhal number tends to decrease with the Reynolds number, but this dependency seems to become weaker as the Reynolds number increases. It was suggested by Nathan et al. (1996) that compressibility effects are the probable cause of the Reynolds number dependence. This effect was not examined by Guo et al. (2001) since their investigations assume incompressible flow only. The situation is different when the expansion ratio is increased. For the case of  $E = 6.0$ , a minimum Reynolds number of about  $10^5$  is necessary to sustain regular oscillations, otherwise a complex oscillation occurs.

## EFFECT OF THE EXPANSION RATIO

A well-defined Strouhal number provides a basis for further quantifying each region. For axisymmetric sudden expansion flows, the Reynolds number at the inlet is larger than that at the outlet by a factor equal to the expansion ratio. The difference in Reynolds numbers increases as the expansion ratio increases. Most investigations use the Reynolds number defined at the inlet for convenience. However, when the expansion ratio is large, the downstream Reynolds number becomes so small that the flow may fall into the transitional region. According to Guo et al. (2001), for the range of expansion ratios considered from 3.0 to 6.0, two modes of oscillations can be observed. For cases between  $E = 3.95$  and 6.0, a combination of a regular precession and a flapping motion in a rotating frame of reference can always be identified. In this case, two separate Strouhal numbers can be determined, which correspond to the precession and the flapping frequencies. This state is named the regular precession mode (PJ), since the precession dominates over the flapping motion in most of the domain. When the expansion ratio is further reduced to 3.0 and 3.95, both the regular precession and a quasi-flapping oscillation could be predicted in separate computational runs.

## SOLVED VARIANTS

Square and rectangular cross section geometries that are of interest here are depicted in **Fig. 3**. There are in total five variants that have been compared. All these variants are based on the expansion ratio  $E = 5$ , and  $Re = 1.25 \cdot 10^5$ . Therefore the used aspect ratios are  $1 < H/D < 2$  and  $l/D = 10$ . The first three variants were defined as square-section with expansion of the main chamber, and two further variants have been defined with a rectangular main chamber (and no further expansion of the main chamber). Tab. 2 gives an overview of the variants. Here  $\alpha$  stands for the expansion angle of the main chamber and  $H$  and  $D$  are the width and depth (see Fig. 2) of the chamber respectively.

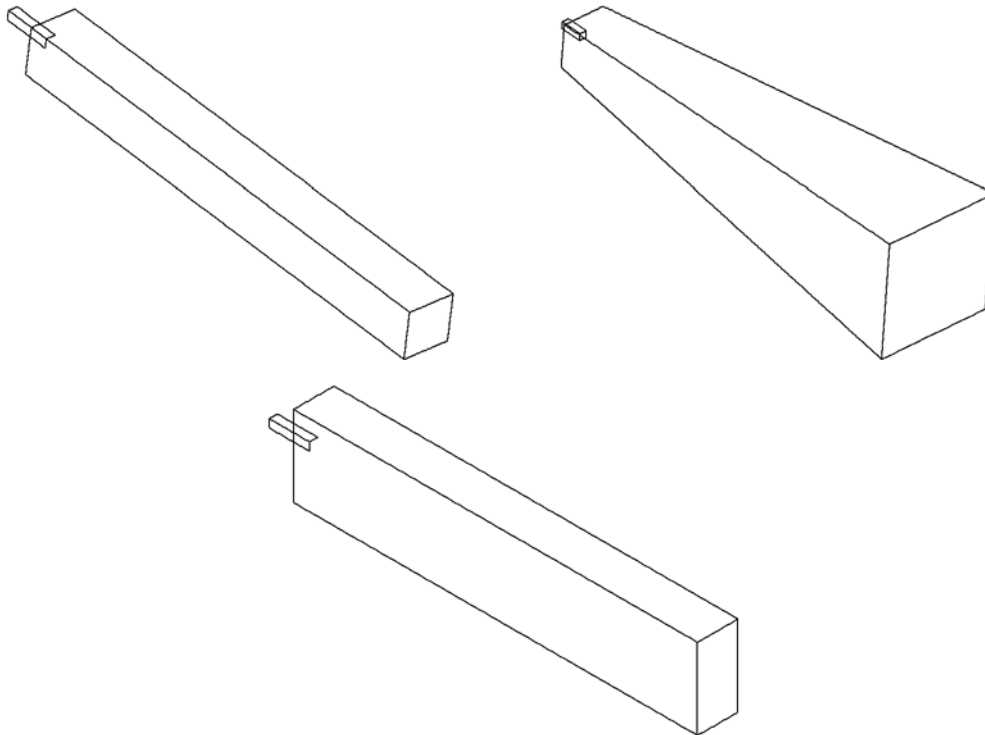

Figure 3. Square section geometry (V1); Square section geometry, expansion of the main chamber (V2, V3); Rectangular section geometry (V4, V5)

### Flow field visualization

Although the flow field changes with time, the fundamental flow features remain the same. Figure 4 illustrates instantaneous streaklines originating from the inlet tube. Variants 2 and 3 with the expansion of main chamber are shown in the middle and right and basic variant 1 is shown on the left. The fluid emanating from the inflow area separates at the expansion, departs from the central axis and moves toward the main chamber wall. Approximately at the point of  $x = 3.5D$  a recirculation zone occurs. In variant 2 the recirculation zone is a ring like shaped configuration. In this case the ring recirculation zone occurs between points  $x = 1.8D$  and  $5D$ . For variant 3 the recirculation zone occurs approximately between  $x = 0.75D$  and  $7.5D$ .

Tables 3 and 4 show the calculated jet oscillation frequencies and consequently Strouhal numbers  $St$  for all solved variants. The fluid movement has been monitored at a central point halfway downstream of the chamber at  $x = 0.5L$ . From the transient monitor point values the frequency respectively the Strouhal number was derived. In cases V1, V2, and V3 one can observe two types of movement: precession and flapping movement. In variants V4 and V5 one finds only the flapping mode. When discussing the table of frequencies it can be concluded that further expansion of the main chamber leads to stabilization of the jet (frequencies decrease when expansion angle increases) as well as increasing the ratio  $D/H$  in cases with rectangular geometries (and without further expansion of the main chamber).

Table 3. Flapping movement parameters

	V1	V2	V3	V4	V5
frequency [1/s]	7.1	2.2	0.8	3.25	2.9
St [-]	0.142	0.151	0.121	0.080	0.082
D/H [-]	1	1	1	1.5	2

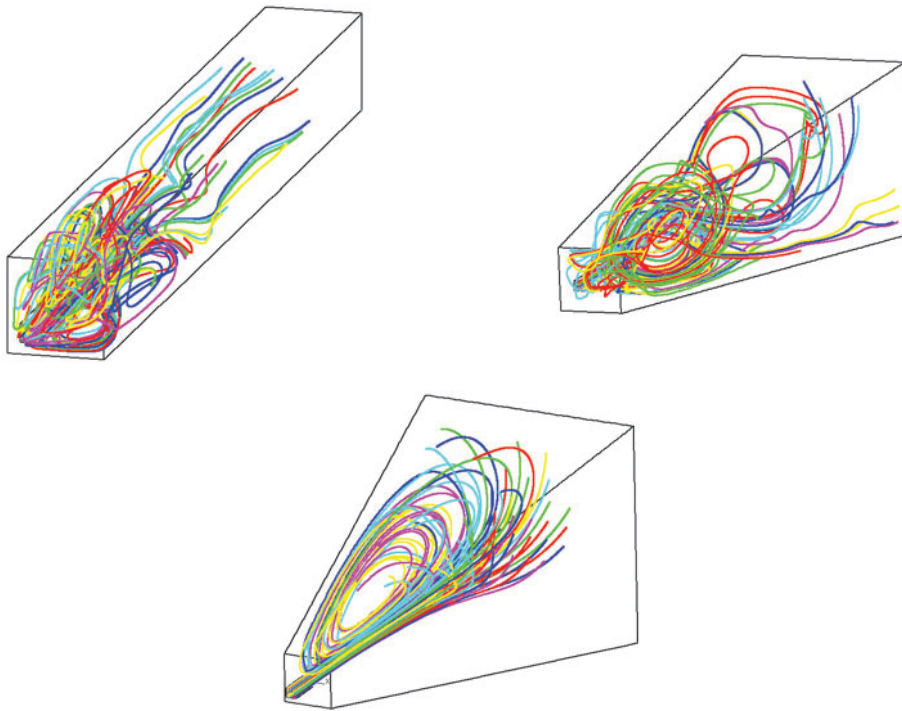

Figure 4. Instantaneous streaklines; upper left: variant V1,  $E = 5$ ,  $Re = 2.5 \cdot 10^5$ ; upper right: variant V2,  $E = 5$ ,  $Re = 2.5 \cdot 10^5$ ; lower: variant V3,  $E = 5$ ,  $Re = 2.5 \cdot 10^5$

Table 4. Precession movement parameters

	V1	V2	V3	V4	V5
frequency [1/s]	3	1	0.5	no precession	no precession
St [-]	0.060	0.068	0.076	-	-
D/H [-]	1	1	1	1.5	2

## CONCLUSIONS

The paper describes the time dependent jet flow behaviour in non-circular cross section chambers, where the fluid is injected into the main chamber by a central nozzle. The flow field is studied by means of computational fluid dynamics.

Five different geometrical variants have been computed. Square and rectangular cross section geometries with and without streamwise expansion have been compared. All of these variants have been calculated based on a Reynolds number  $Re = 2.5 \cdot 10^4$  and an expansion ratio  $E = 5$ . The aspect ratio under investigation was  $1 < H/D < 2$  and  $L/D = 10$ .

The characteristic behavior of the jet is formed by a recirculating movement in the main chamber. However, the shape and range of recirculation zone differs from variant to variant. One can observe this strong recirculation in all variants approximately between points  $x = 0.1D$  and  $7D$ . When describing the jet behavior at a central point halfway downstream ( $0.5L$ ), two different types of movements are found, namely precession and flapping movement. These can be examined by the derived frequency of the movement and the Strouhal number. Calculations show that further expansion of the main chamber leads to decrement of the flapping and precession frequency in general, as well as an increase of the ratio of  $D/H$  in case of rectangular geometries leads to a decrease of the flapping movement.

## ACKNOWLEDGEMENT

This work has been performed within a project funded by the European Commission in a Marie-Curie host fellowship program at the University of Bremen. The support from the EC is gratefully acknowledged.

**NOTATION**

C	coefficient
d	cylindrical chamber inlet diameter
D	spray chamber diameter
E	expansion ratio
f	oscillation frequency
H, D	flow chamber cross section dimension
L	length of flow chamber
M	momentum flux
n	exponent
Re	Reynolds number
St	Strouhal number
U	inflow velocity
x	coordinate

**Greek**

$\rho$	density
--------	---------

**REFERENCES**

- Fritsching, U.: Droplets and Particles in Sprays: Tailoring Particle Properties within Spray Processes, *China Particuology* (2005) 1-2, 125-133.
- Gillandt, I.; Fritsching, U. and Bauckhage, K.: Measurement of Phase Interaction in Dispersed Gas / Particle Two Phase Flow, *Int. J. Multiphase Flow* 27 (2001), 1313-1332.
- Guo, B.; Langrish, T. and Fletcher, D.: Numerical Simulation of Unsteady Turbulent Flow in Axisymmetric Sudden Expansions, *Journal of Fluids Engineering* 123 (2001) 3, 574-587.
- Hallet, W. L. H. and Gunther, R.: Flow and Mixing in Swirling Flow in a sudden Expansion. *The Canadian Journal of Mechanical Engineering*, 62 (1998), 119-122.
- Heinlein, J.; Schulte, G.; Fritsching, U. and Guardani, R.: Mapping the structure of a liquid spray by means of neural networks, *Chem. Eng. Proc.*, 46 (2007), 1357-1364.
- Hill, S. J.; Nathan, G. J. and Luxton, R. E.: Precession in Axisymmetric Confined jets, *Proceedings of 12th Australian Fluid Mechanics Conference*, pp. 135-138, December 1995, Sydney
- Nathan, G. J.; Hill, S. J. and Luxton, R. E.: An Axisymmetric Fluidic Nozzle to Generate Jet Precession, *Journal of Fluid Mechanics*, 370 (1998), 347-380
- Rajaratnam, N.: *Turbulent Jets*, Elsevier Scientific Publishing Company, Amsterdam, 1976.
- Rotta, J.C.: *Turbulente Strömungen*, B.G. Teubner, Stuttgart, 1972.

