

# Bearings for noiseless trains and to protect oil platforms against earthquakes

*John McClintock*

An elastomeric bearing is an elastic component that supports and guides the moving part of a machine or similar in conjunction with a static part, giving the moving part a certain freedom of movement by absorbing bumps and vibrations. They can be used to make high-speed trains noiseless and to protect oil platforms against earthquakes.

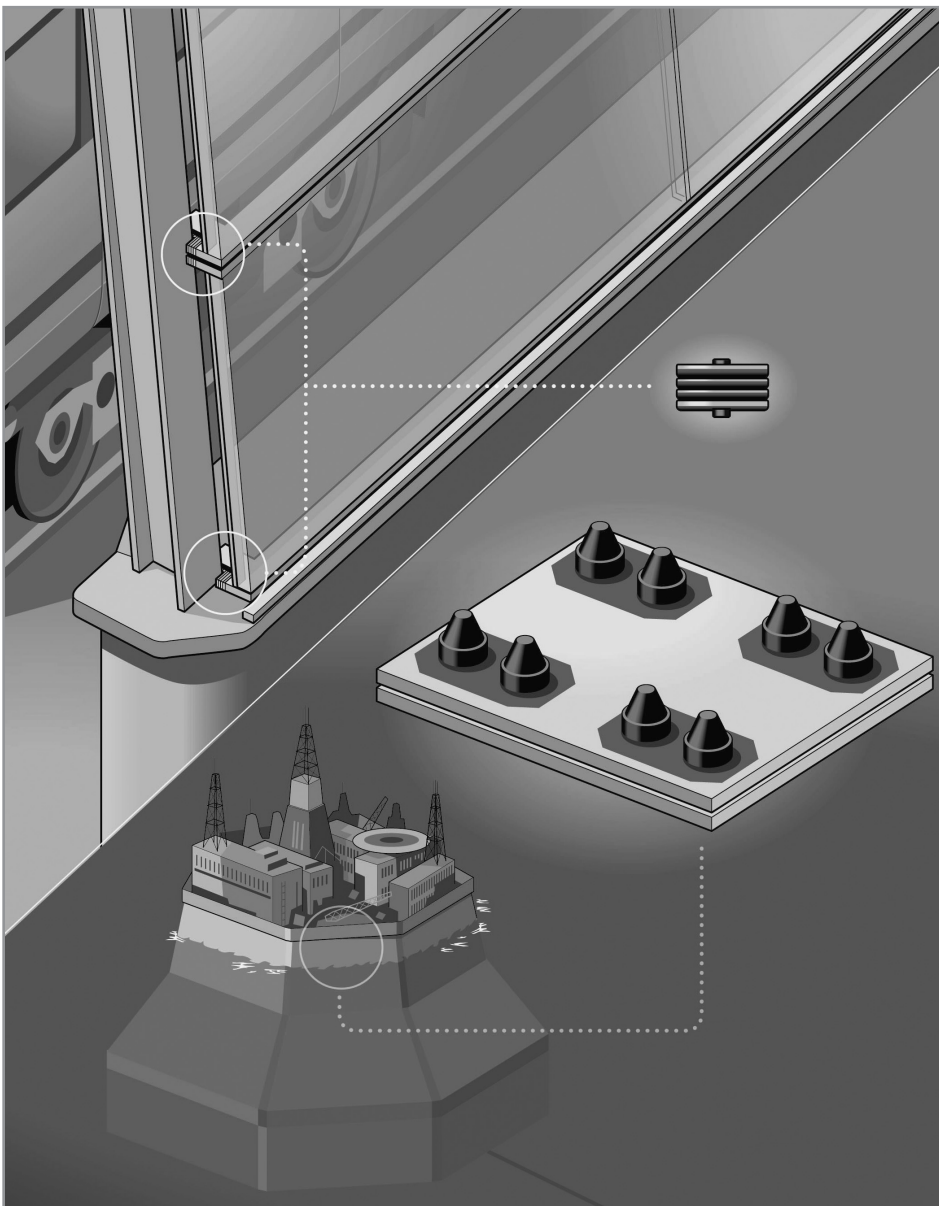

1. The smallest bearing: Two small elastomeric bearings are clamped on each corner of the screen panel to reduce deformation.
  2. The largest bearing: Trelleborg Engineered Systems' largest elastomeric bearing is positioned between the oil platform and a new module to protect it from earthquakes.
- Illustration: Kjell Eriksson*

*The smallest bearing:* High-speed trains are being introduced in the Netherlands, which has led to the building of “noise reduction screens” in densely populated areas along the railroad. But the speeding trains cause pressure and suction waves that deform the screens, which have been set up along stretches totaling some 30 km.

To control the loads and stresses in the structure, Trelleborg Engineered Systems and customer BAM Redubel found that clamping the screen panels with small laminated bearings, two on each corner, considerably reduced the deforming forces.

Trelleborg will deliver about 130,000 of these bearings, the smallest it currently manufactures. Each one measures 55 x 35 x 25 mm.

*The largest bearing* made by Trelleborg Engineered Systems is used

to protect two new modules on an existing oil platform from earthquakes. The platform is part of a development of offshore gas- and oilfields on the northeastern shelf of Sakhalin Island, Russia, north of Japan. Phase II of the project involves adding facilities to allow year-round export of crude oil and natural gas from the platform via sub-sea oil and gas pipelines.

To withstand earthquakes, the four bearing structures were specially designed and manufactured for ABB Lummus Global to be able to slide more than 400 mm in all horizontal directions. The largest bearing measures 3,500 x 2,500 x 1,100 mm. According to the company, this is probably the largest bearing structure containing elastomeric bearings ever built.

#### **LOW FREQUENCY NOISE DOESN'T COUNT**

Sympathetic council chiefs are powerless to help a Cramlington community enduring a nightmare of white noise from a nearby factory. Planning and environmental protection officers from Blyth Valley Council have been investigating the constant droning sound which residents say is coming from the Avery Dennison unit on Nelson Industrial Estate. But after a thorough analysis of the premises, officers have concluded that the noise is well below the World Health Organisation (WHO) standard to warrant taking legal action. Residents living on Northburn estate submitted a petition to the council complaining about the ambient noise, which they feel is effecting their health, infringing human rights and making lives a misery. Petitioners even say the humming is worse than when it first started nearly a year ago. A report was presented to cabinet members showing the extent of assessment undertaken by officers. It said: “The industrial noise monitored from the Northburn estate was below the WHO standard and therefore would be highly unlikely to constitute a statutory nuisance. The results of the investigation, mean there are no legal actions available to the council in respect of Integrated Pollution Prevention and Control (IPPC), or any other statutory regime.” The report also gave details of the possibility that once attention is drawn to a noise, residents can ‘tune in’ to a sound which then becomes personally annoying, while never even approaching a breach in regulations.